

SITE FURNISHINGS

ROLLER COASTER BIKE RACK





Available Finishes

- Galvanized
- Powder Coated
- Stainless Steel

MODEL #LA-WLBR-5 5-SPACE RACK (60 lbs)
 MODEL #LA-WLBR-7 7-SPACE RACK (90 lbs)
 MODEL #LA-WLBR-9 9-SPACE RACK (125 lbs)
 MODEL #LA-WLBR-11 11-SPACE RACK (155 lbs)
 MODEL #LA-WLBR-13 13-SPACE RACK (175 lbs)

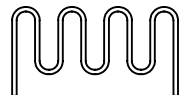

LA-WLBR-9
SHOWN

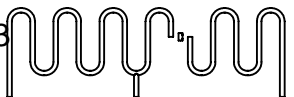
ROLLER COASTER BIKE RACK	DIM. "A" APPROX.
LA-WLBR-5 	38"
LA-WLBR-7 	62"
LA-WLBR-9 	87"
LA-WLBR-11 	109"
LA-WLBR-13 	139"

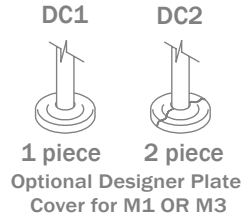
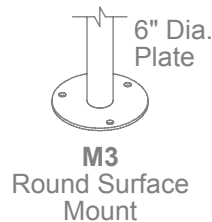
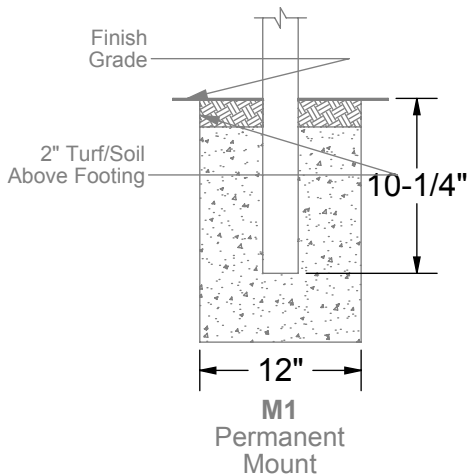
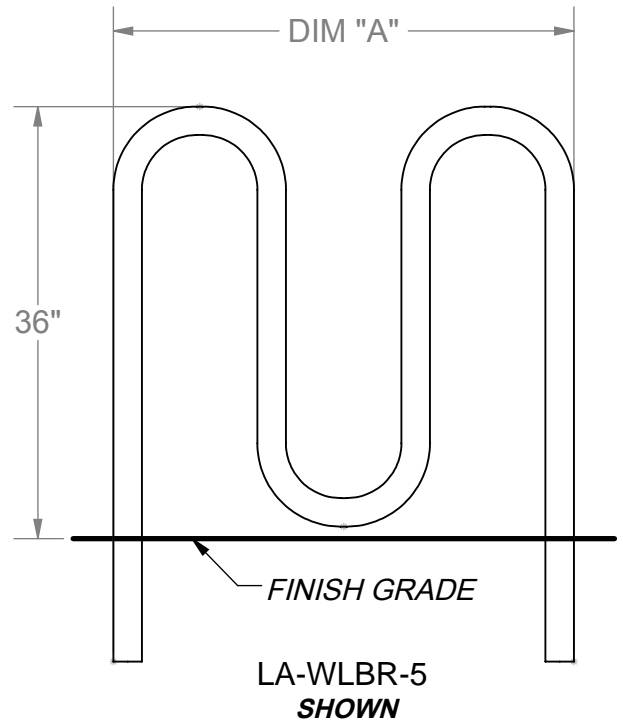

SCALE: N.T.S.	SPECIFICATION / INSTALLATION INSTRUCTIONS
DATE: 8/5/15	<i>ROLLER COASTER BIKE RACK</i>
DRAWN: MT	
REV: SS81617	
SHEET: 1 of 2	LA-WLBR

SITE FURNISHINGS

Both the galvanized and stainless steel were selected for their superior corrosion and rust resistance. All three finishes are low maintenance making any selection an excellent choice for your application. Both steel types are produced using 50% or more recycled materials and our powder coat is also an ultra-low voc making our materials eco-friendly.

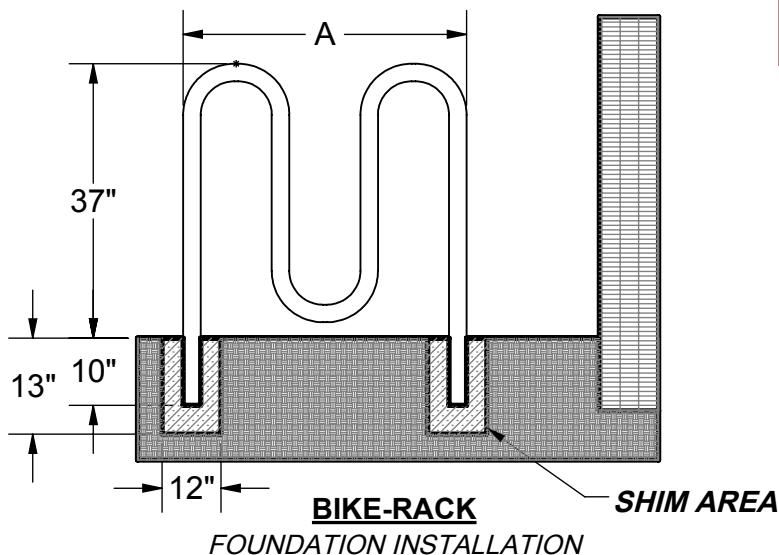

NOTE: Footing sizes are based on average soil conditions. Loose and/or sandy soil is not average & footing sizes must be increased accordingly to meet soil conditions & local building codes & specifications.

Surface Mount Option: Surface mount plates are welded to rack for quick & easy installation. Pick desired location & anchor to surface using holes in mounting plates as a guide. Anchors not included.

SPECIFICATIONS:

The Roller Coaster bike rack is a heavy-duty, multiple loop style bike rack that will fit in all areas for single or double side load. It can be surface-mounted or permanently installed in-ground.

MATERIAL: Manufactured from 2-3/8" O.D. heavy-duty 10 gauge galvanized steel tube ASTM A-787. (or)
Manufactured from 2-3/8" O.D. Stainless Steel.

FINISH: Coating specs meet ASTM A-653.

WARRANTY PERIOD: 10 YEARS

INSTALLATION INSTRUCTIONS:

Note: All Model 1602 Roller Coaster Bike Racks require a concrete anchor for in-ground installation. Optional surface mount plate must be designated at time of order. Mounting hardware not included.

- 1) Determine location where bike rack is to be installed. If locating near building or wall. (See detail above.)
- 2) Dig hole for footing (see footing detail). **NOTE:** Use rack for spacing.
- 3) Set legs of bike rack in center of holes & shim from below or fill such that the top of the bike rack is 36" above finish grade. Plumb the bike rack to true vertical & brace. **NOTE:** Place a 2x4 on the ground under the bike rack to shim bottom of bike rack ensuring the correct height is kept while pouring concrete footing.
- 4) Pour concrete up to finish grade. Allow concrete to set for 3 days before removal of bracing.



SCALE: N.T.S.	SPECIFICATION / INSTALLATION INSTRUCTIONS
DATE: 8/5/15	<i>ROLLER COASTER BIKE RACK</i>
DRAWN: MT	
REV: SS81617	
SHEET: 2 of 2	LA-WLBR