

ITEM NO.	PART NUMBER	DESCRIPTION	QTY.
1	VCITIPNROLLSPACER	2.5" X 1.0" UHMW ROLLER SPACER PAD	9
2	VCITPNRCWL	CASTER WHEEL WITH BRAKE 3/8-16 x 1-1/2" STEM x 4"	6
3	HWFLHD38114	3/8-16 x 1-1/4" FLAT HEAD SOCKET CAP SCREW 18.8	9
4	HWLN38	3/8-16 NYLOCK INSERT NUT	15
5	HWFLWA38	3/8" FLAT WASHER	21

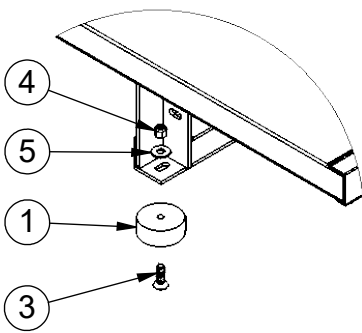

DETAIL A

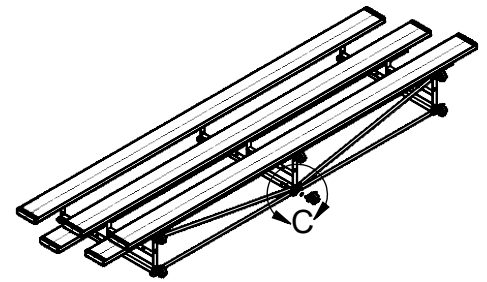
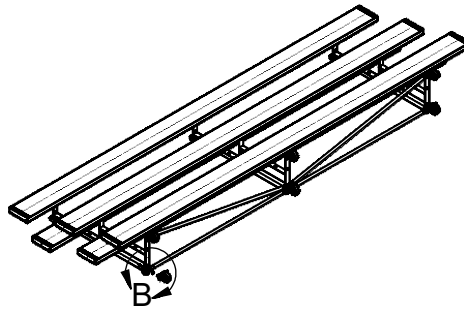
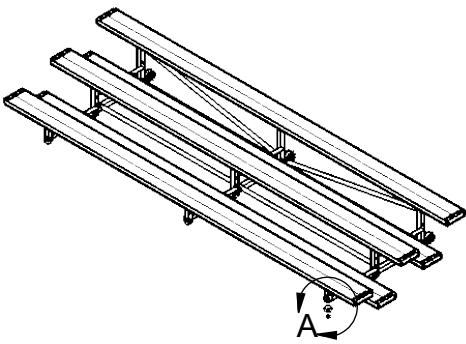
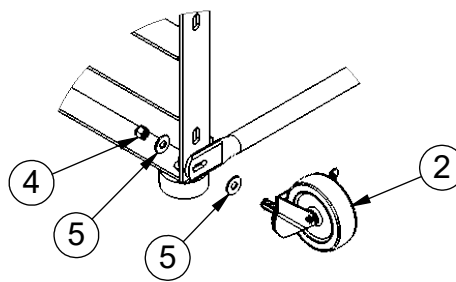

DETAIL B

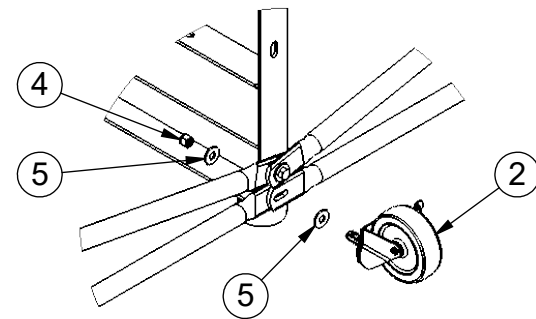

DETAIL C

Install transport system: mount the wheels and frame pads as shown. Frame pads are made of 2-1/2" x 1" thick plastic. Pads have counter sunk holes and are attached with flathead bolts. Caster wheels with brakes are 1" thick x 4" high wheels on a swivel base. Each caster wheel gets (2) washers and a nut. If there is interference of the rotation of the caster wheel, remove a washer from caster wheel.



Date: 11/14/22
 Rev:
 Drawn: CW
 Sheet: 1 of 1

PRODUCT NAME
 TIP AND ROLL WHEEL CASTER/FRAME PAD
 INSTALLATION INSTRUCTIONS

MODEL NO.

LA-PN203-RB15