

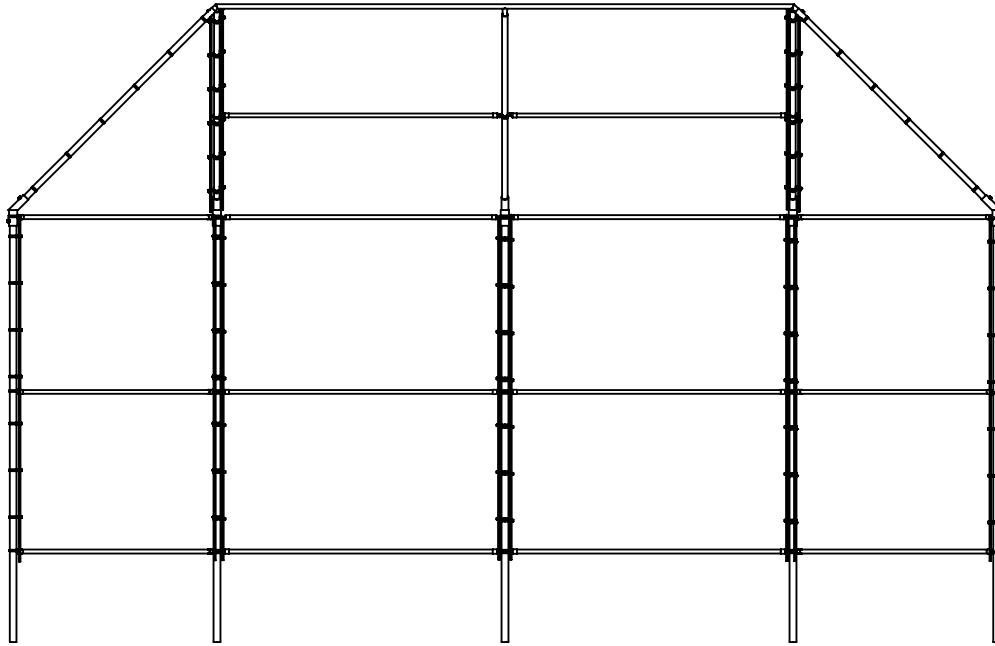

PERMANENT HOODED BACKSTOP INSTALLATION INSTRUCTIONS MODEL #LA-1235T



Description: A heavy duty backstop shipped unassembled with all parts and instructions for quick assembly.

Materials: All pipe and fittings are galvanized steel. Sizes given are outside diameter and exposed ends are capped.

<u>Specifications</u>	<u>Size</u>
Vertical Posts	2-7/8"
Horizontal Rails	1-5/8"
Top Hood Rails	1-7/8"
Hood Angle Posts	2-3/8"

 <p>www.LASTEELCRAFT.com 1-800-371-2438</p>	Date: 3/7/23	PRODUCT NAME HOODED BACKSTOP
	Rev:	
	Drawn: CW	LA-1235T-SPEC
	Sheet: 1 of 7	

ITEM NO.	PART NUMBER	DESCRIPTION	QTY.
1	RT-001-1234-180-G	LEG POST 2-7/8" O.D. x 12GA x 180" GAL. TUBE	5
2	RT-003-1234-112.5-G	STIFFENER 1-5/8" O.D. x 16GA x 112-1/2" GAL. TUBE	10
3	VCIBB278	2-7/8" BRACE BAND	16
4	VCIRAIEND158	1-5/8 ID RAIL END	28
5	CI12ELB1	HOODED BACKSTOP ELBOW FITTING	5
6	ASA-0501-1230-G	HOOD ANGLE ϕ 2-3/8" ASSEMBLY	5
7	ASA-0502-1230-G	HOOD CROWN ASSEMBLY	1
8	VCIBB238	2-3/8" BRACE BAND	4
9	VCIBB35	3-1/2" BRACE BAND	8
10	RT-008-1234-112-G	STIFFENER 1-5/8" O.D. x 16 GA x 112" GAL. TUBE	4
11	HWCB5161	5/16"-18 x 1" CARRIAGE BOLT	120
12	HWSC581	5/8" SS SET SCREW	15
13	HWFLWA516	5/16" USS FLAT WASHER	120
14	HWLN516	5/16"-18 LOCK NUT	120
15	VCITEN278	2-7/8" TENSION BAND	56
16	VCITBAR12	12' x 3/4" TENSION BAR (142")	8
17	VCITEN238	2-3/8" TENSION BAND	36
18	VCITBAR10	10' x 3/4" TENSION BAR (118")	6
19	RMMESHGA21110	2" x 11GA x 10' GAL MESH	40'
20	RMMESHGA2912	2" x 9GA x 12' GAL MESH	40'
21	VCITIEWIRE	TIE DOWN WIRE 10-1/2" x 12GA WITH HOOK	185

 <p>Steelcraft ELEMENTS FOR LIFE OUTSIDE[®]</p> <p>www.LASTEELCRAFT.com 1-800-371-2438</p>	Date:	3/7/23	PRODUCT NAME
	Rev:		HOODED BACKSTOP
	Drawn:	CW	MODEL NO.
	Sheet:	2 of 7	LA-1235T-SPEC

FOOTING DETAIL

- 1) Determine the location of the backstop so the rear panel is perpendicular to a line running from 2nd base through home plate and the wings are parallel with the sides of the diamond.
- 2) Dig holes according to Footing Plan below and Footing Detail. Place all the posts in the holes resting on the blocks. Each post shall be 12'-0" above ground and 10'-0" on center. Place a horizontal stiffener on the ground between each of the posts. Place a rail end fitting on each end of the stiffeners. Place a brace band over each post adjacent to each rail end fitting. Bolt the rail end fitting to the corresponding brace band. Make sure the horizontal stiffeners fit into the rail end fittings at least 1".

NOTE: All carriage bolt heads are facing the playing field.

- 3) With the proper spacing established, plumb all the posts and pour the concrete footings up to 2" of finish grade and let set for three days before removal of bracing.

NOTE: Footing sizes are based on the assumed soil bearing pressures from IBC 1807.

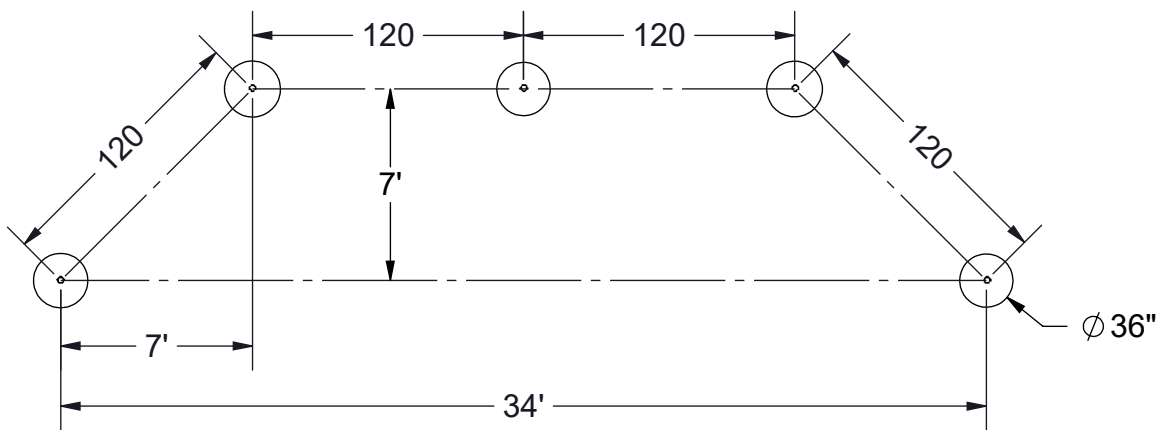
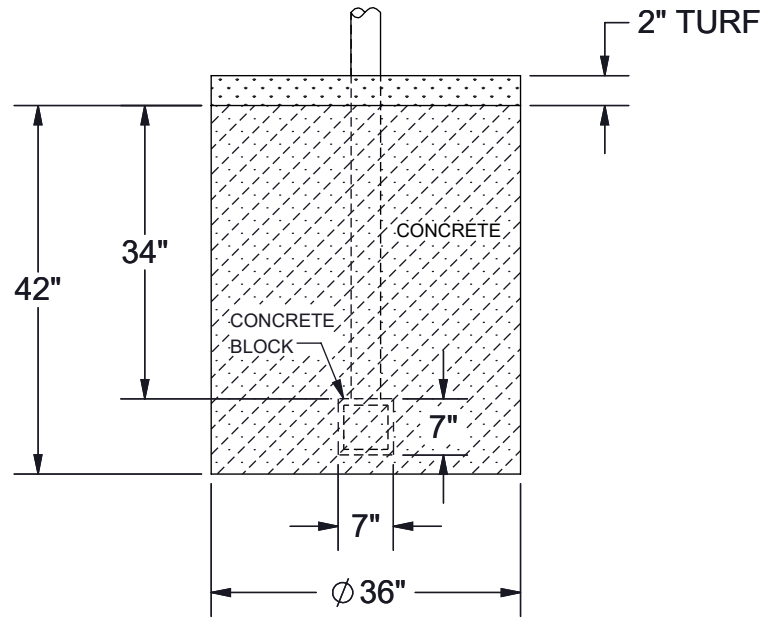
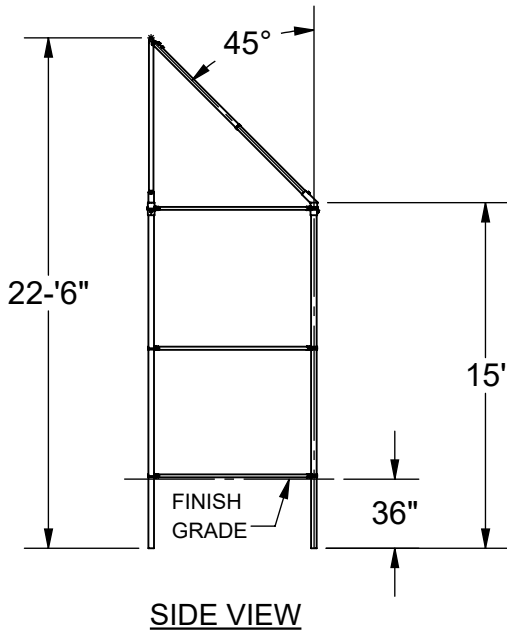

 <p>Steelcraft ELEMENTS FOR LIFE OUTSIDE[®] www.LASTEELCRAFT.com 1-800-371-2438</p>	Date: 3/7/23	PRODUCT NAME
	Rev:	HOODED BACKSTOP
	Drawn: CW	
	Sheet: 3 of 7	MODEL NO.

INSTALLATION INSTRUCTIONS

4) Check materials received with the BOM to make sure that all components are included and to assure that the unit is complete.

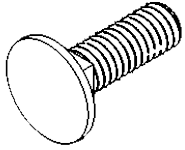

HWCB516

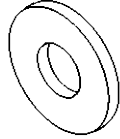

HWFLWA516

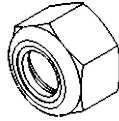

HWLN516

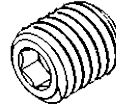

HWSC581

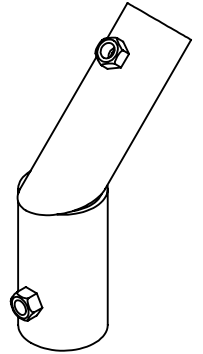

CI12ELB1



VCITBAR10/VCITBAR12

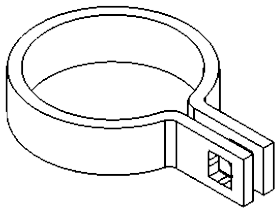

VCIBB238

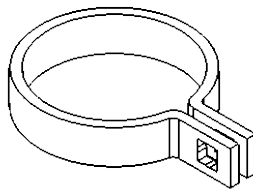

VCIBB278

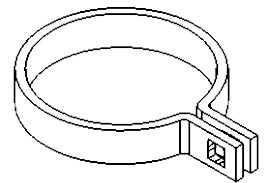

VCIBB35

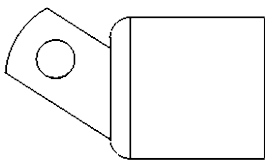

VCIRAILEND158

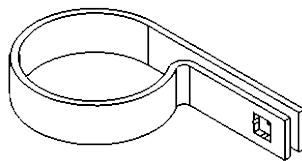

VCITEN238

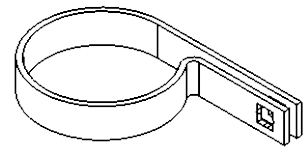

VCITEN278

 <p>Steelcraft ELEMENTS FOR LIFE OUTSIDE[®] www.LASTEELCRAFT.com 1-800-371-2438</p>	Date: 3/7/23	PRODUCT NAME
	Rev:	HOODED BACKSTOP
	Drawn: CW	MODEL NO.
	Sheet: 4 of 7	LA-1235T-SPEC

INSTALLATION INSTRUCTIONS

5) Put the entire Backstop together, starting at the top and working from left to right.
 Slide the Brace Bands (3) (9), Tension Bands (15) and Hooded Backstop Elbow Fittings (5) onto the vertical posts.

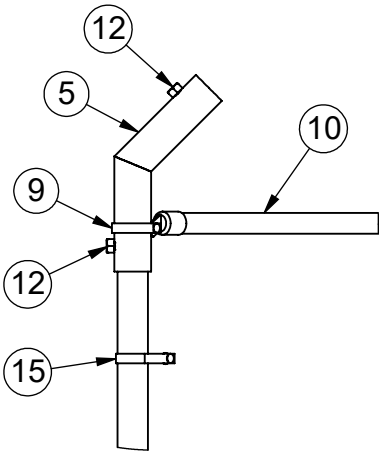

DETAIL A

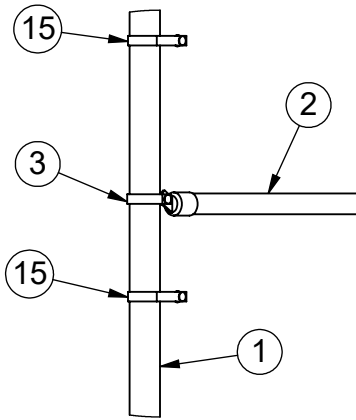

DETAIL B

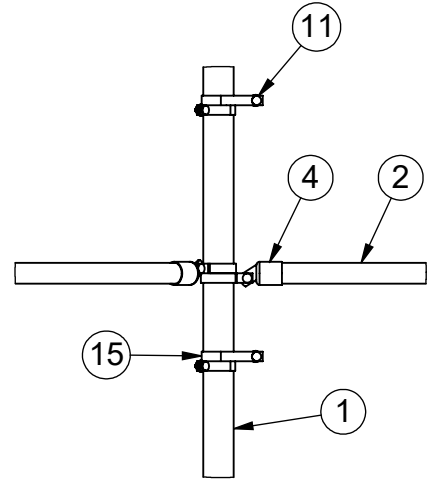

DETAIL C

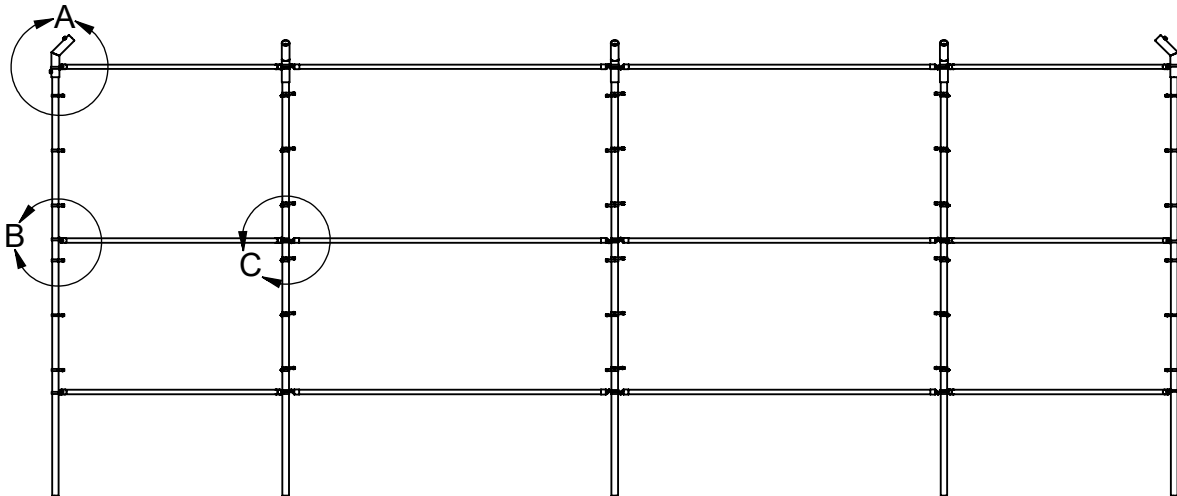

FRONT VIEW
 POSTS AND HORIZONTAL RAILS

 <p>Steelcraft <small>ELEMENTS FOR LIFE OUTSIDE</small></p> <p>www.LASTEELCRAFT.com 1-800-371-2438</p>	Date: 3/7/23	PRODUCT NAME
	Rev:	HOODED BACKSTOP
	Drawn: CW	MODEL NO.
	Sheet: 5 of 7	LA-1235T-SPEC

INSTALLATION INSTRUCTIONS

- 6) Start building the hood by working from left to right. Slide 2-3/8" Tension Bands (17) onto the Hood Angle Assemblies (6) with (6) on the outer angle and (12) on the inner angle, repeating for the right side. Install 2-3/8" Brace Bands (8) onto the Hood Angle Assemblies as shown in Detail F as well as the other two Hood Angle Assemblies. Install the Stiffeners as shown below. Stiffeners use 2-3/8" Brace Bands, 1-5/8" Rail Ends with 5/16"-18 x 1" Carriage Bolts, 5/16" Flat Washers and 5/16" Lock Nuts.
- 7) Install the Hood Crown Assembly (7) by sliding the five stubs into the five Hood Angle Assemblies. Install the 5/8" set screws into the hex nuts on the Hood Angle Assemblies and tighten.

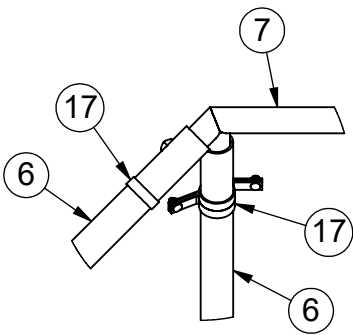

DETAIL D

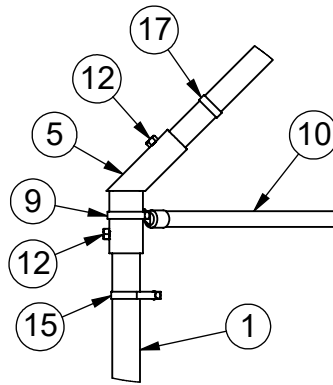

DETAIL E

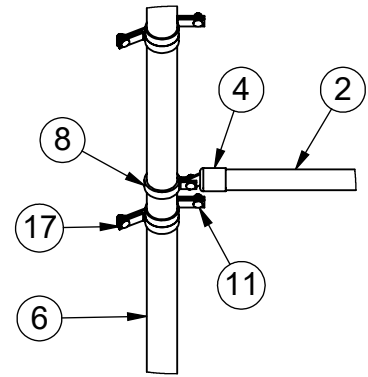

DETAIL F

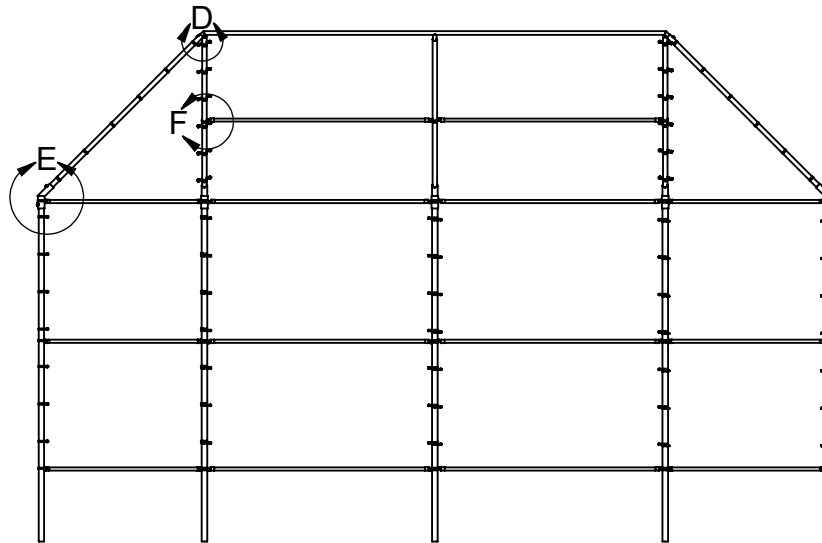

FRONT VIEW
HOOD ASSEMBLY

 <p>Steelcraft ELEMENTS FOR LIFE OUTSIDE™ www.LASTEELCRAFT.com 1-800-371-2438</p>	Date: 3/7/23	PRODUCT NAME
	Rev:	HOODED BACKSTOP
	Drawn: CW	MODEL NO.
	Sheet: 6 of 7	LA-1235T-SPEC

INSTALLATION INSTRUCTIONS

MESH INSTALLATION: Separate the wire mesh as the heavier material (9 GA) is to be used along the rear panel and the wings while the lighter material (11 GA) is to be used on the hood. The mesh is cut to the approximate size and shipped in rolls.

1. Cut four pieces of (9 GA x 12' mesh) 10' wide to be installed between the vertical posts of the rear panel and the wings. Attach each piece of mesh using one 12 foot tension bar on each end of the mesh along with tension bands and bolts provided. Use tension bands on 18 to 20 inch centers. The mesh must be tight; remove strands as necessary to achieve the proper tension.
2. Secure the mesh to the top, center and bottom of the horizontal rails with tie wires every 12 inches.
3. Cut one piece of (11 GA x 10' mesh) 20' wide. Attach the mesh to the rear of the hood panel using one tension bar on each end of the piece along with the tension bands and hardware provided. Tension bands should be used on 18 to 20 inch centers. The mesh must be tight; remove strands as necessary to achieve the proper tension.
4. Secure the mesh to the top, center and bottom of the horizontal rails of the hood supports with tie wires every 12".
5. Cut two 10' long pieces of 11 GA mesh into two triangles to cover the remainder of the hooded area. Use the hood as a template.
6. Install two 10' tension bars in each triangular mesh piece along the two edges where the wire ends are NOT twisted together (knuckled salvage edge). Attach the mesh in the corners of the hood so the edge of the mesh without the tension bar is along the horizontal rail. Use tension bands on 18" to 20" centers to secure to the hood supports. The mesh must be tight; remove one to two strands as necessary to achieve the proper tension.
7. Pull the bottoms of each triangular mesh piece tight and secure with tie wires every 8" to the horizontal rails.
8. Inspect for loose hardware and tighten as necessary. Also look for sharp wires and either cut or turn back into the fabric as necessary.
9. Replace the turf to cover the exposed tops of the footings.

 <p>Steelcraft ELEMENTS FOR LIFE OUTSIDE www.LASTEELCRAFT.com 1-800-371-2438</p>	Date: 3/7/23	PRODUCT NAME
	Rev:	HOODED BACKSTOP
	Drawn: CW	MODEL NO.
	Sheet: 7 of 7	LA-1235T-SPEC