

STEELCRAFT PRODUCTS

P.O. Box 90365 - Pasadena, CA 91109
PHN 626-798-7401 FAX 626-798-1482

MODEL
FLP-40
FOUL POLE

DO NOT SCALE DRAWING

NOTE: POLE IS MADE OF TWO SECTIONS OF 6-5/8" OD Sch 40 PIPE. BOTTOM SECTION IS 24'-0" WITH A SLEEVE TO INSERT INTO THE TOP SECTION. THE BOTTOM SECTION IS SET INTO A CONCRETE FOOTING AS SHOWN. THE TOP SECTION IS 24'-0" THE "SLEEVE" IS A MIN. OF 36" IN EACH SECTION. A LIFTING DEVICE IS REQUIRED FOR INSTALLATION OF TOP SECTION.

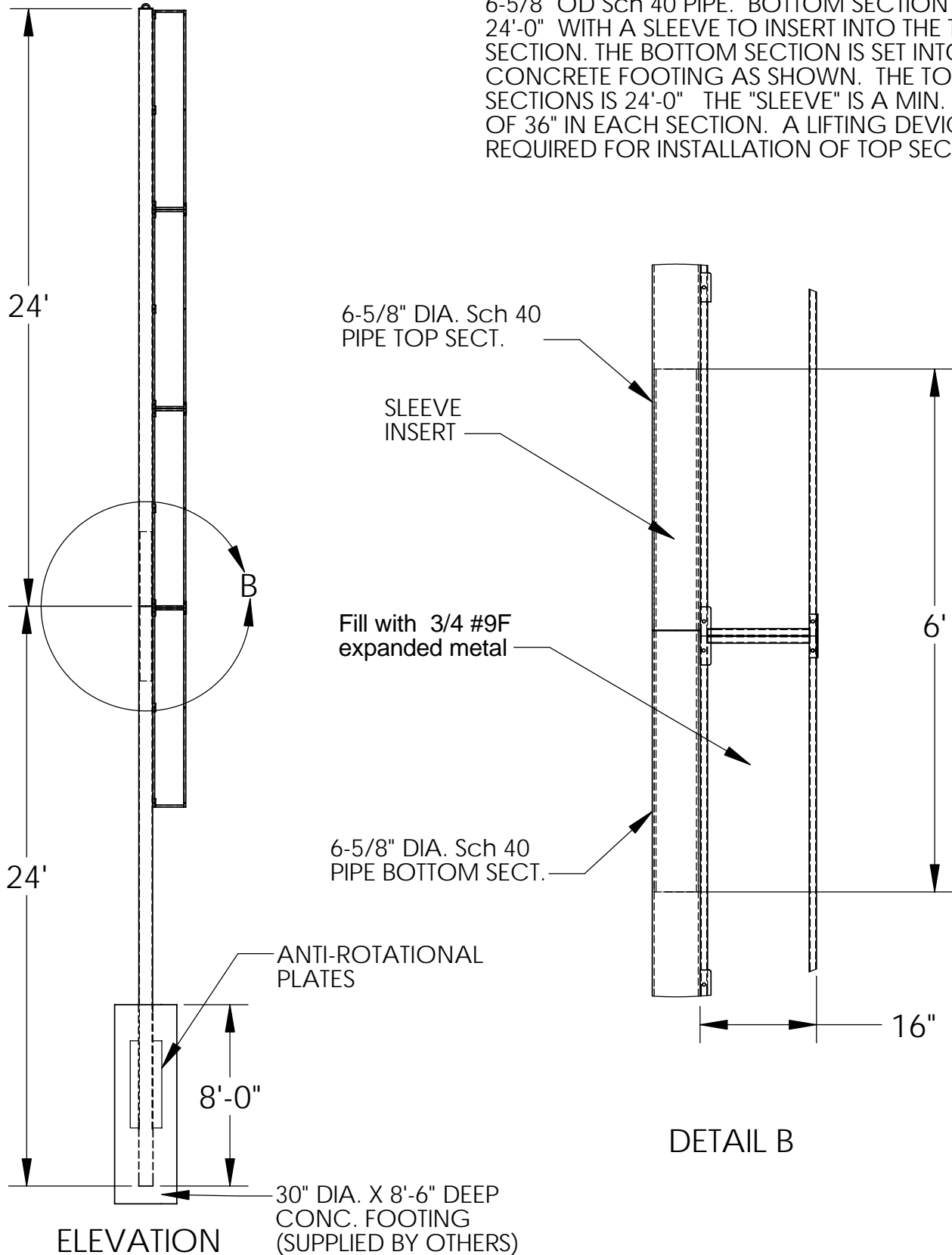

NOTE: SPECIFICATIONS ARE SUBJECT TO CHANGE

DO NOT SCALE DRAWING

DATE: 9/13/06

DRAWN BY: AFS