

STEELCRAFT PRODUCTS

P.O. Box 90365 - Pasadena, CA 91109
PHN 626-798-7401 FAX 626-798-1482

MODEL
AB-62P10
BASEBALL BACKSTOP

DO NOT SCALE DRAWING

2-7/8" OD
FRONT AND BASE
ARCHES

2-3/8" OD
RIBS

1" OD HORIZ.
BRACES

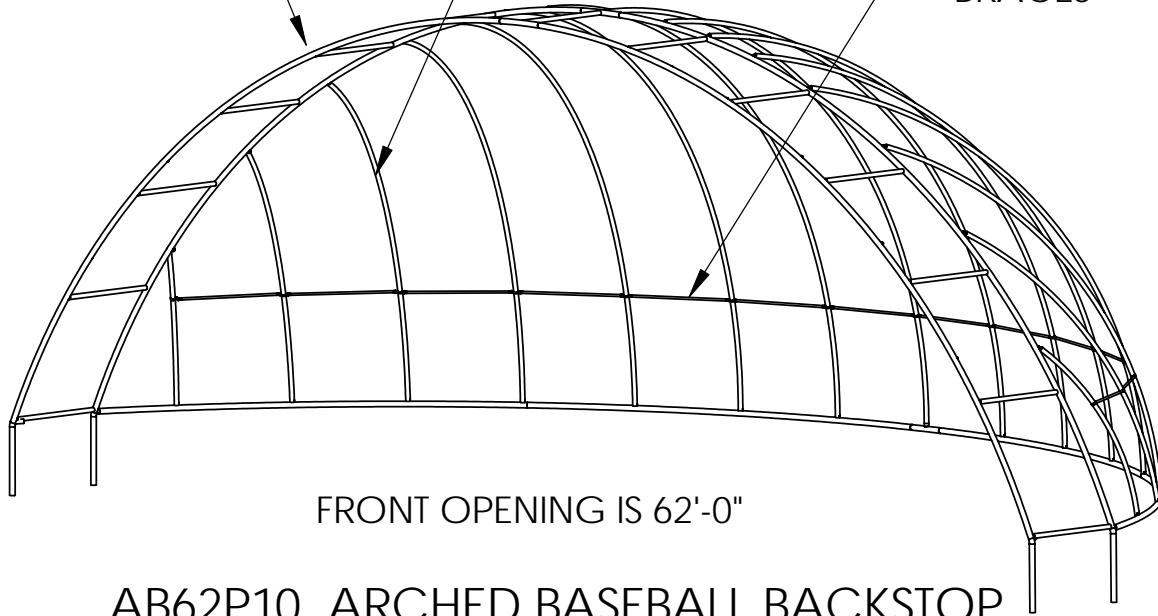

2-3/8" OD
FRONT BRACES

2-3/8" OD
RIBS

1" OD HORIZ.
BRACES

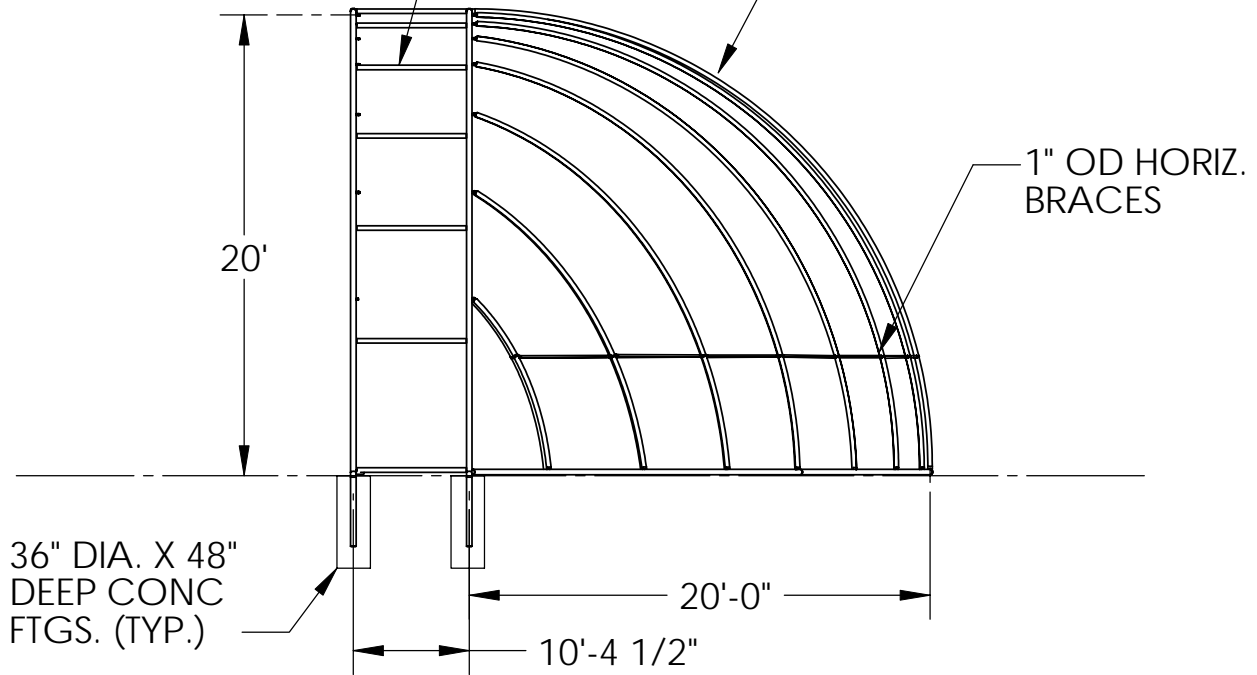

NOTE: SPECIFICATIONS ARE SUBJECT TO CHANGE

DO NOT SCALE DRAWING

DATE: 9/05/06

DRAWN BY: AFS

STEELCRAFT PRODUCTS

P.O. Box 90365 - Pasadena, CA 91109
 PHN 626-798-7401 FAX 626-798-1482

MODEL
 AB-62P10
 EXTENSION DETAILS

DO NOT SCALE DRAWING

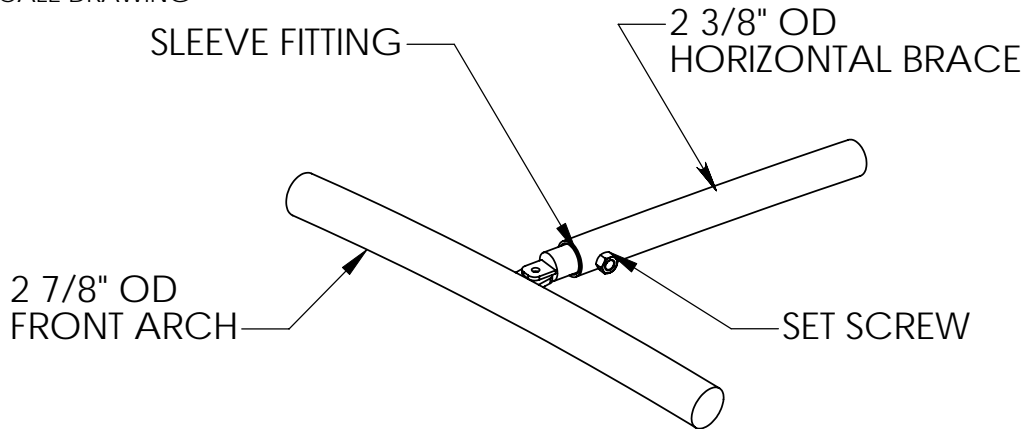

HORIZONTAL BRACE CONNECTION

PARTS

ITEM	QUANT	DESCRIPTION
A	1	CENTER FRONT TOP SECTION: 2-7/8" od GALV PIPE X w/ INTERNAL FITTINGS ON EACH END AND 1 STUB FITTINGS WELDED AT CENTER TO RECEIVE THE CENTER VERTICAL RIB.
B	2	LEFT AND RIGHT SIDE FRONT ARCH TOP SECTIONS MADE OF 2-7/8" OD GALV. PIPE. BOTTOM END EXTENDS INTO FOOTING
C	2	LEFT AND RIGHT SIDE FRONT ARCH TOP SECTIONS MADE OF 2-7/8" OD GALV. PIPE. BOTTOM END EXTENDS INTO FOOTING
D	13	HORIZONTAL STIFFENERS (BRACES): 2-3/8" OD @ 6'-6" GALV. PIPE.
E	42	2-7/8" TENSION BANDS
F	80	2" - 9 ga. X 10 ft. WIDE CHAIN LINK FABRIC
G	80	5/16" X 1-1/4" CC BOLT w/ LOCK NUT
H	18	10 ft. TENSION BARS

INSTRUCTIONS

1. INSTALL FRONT ARCH SIMILAR TO FRONT ARCH OF THE BASE BACKSTOP. THE EXTENSION ARCH IS TO BE 10'-4 1/2" IN FRONT OF THE BASE BACKSTOP.
2. INSERT THE TOP FRONT BRACE IN THE STUB ON THE FRONT BASE ARCH AND THE EXTENSION ARCH. TIGHTEN THE SET SCREWS.
3. THE EXTENSION BRACES ARE TO BE SPACED AT APPROXIMATELY 7'-6" C-C. PLACE A BRACE BAND AT THIS SPACING TO RECEIVE THE EIGHT REMAINING FRONT BRACES.
4. PLACE THE SLIP FITTING IN EACH END OF THE FRONT BRACE AND ATTACH TO THE BRACE BANDS USING HARDWARE PROVIDED. ADJUST TO MAKE THE FRONT ARCH PERPENDICULAR AND TIGHTEN SET SCREWS.
5. PLACE TENSION BANDS AT APPROXIMATELY 5'-0" SPACING. PLACE THE CHAIN LINK FABRIC ON THE TOP OF THE EXTENSION AND ATTACH TO THE TENSION BARS/BANDS.

NOTE: SPECIFICATIONS ARE SUBJECT TO CHANGE

DO NOT SCALE DRAWING

DATE: 9/05/06

DRAWN BY: AFS