

# STEELCRAFT PRODUCTS

P.O. Box 90365 - Pasadena, CA 91109  
PHN 626-798-7401 FAX 626-798-1482

MODEL  
810JH-4S  
PORTABLE  
BASEBALL BACKSTOP

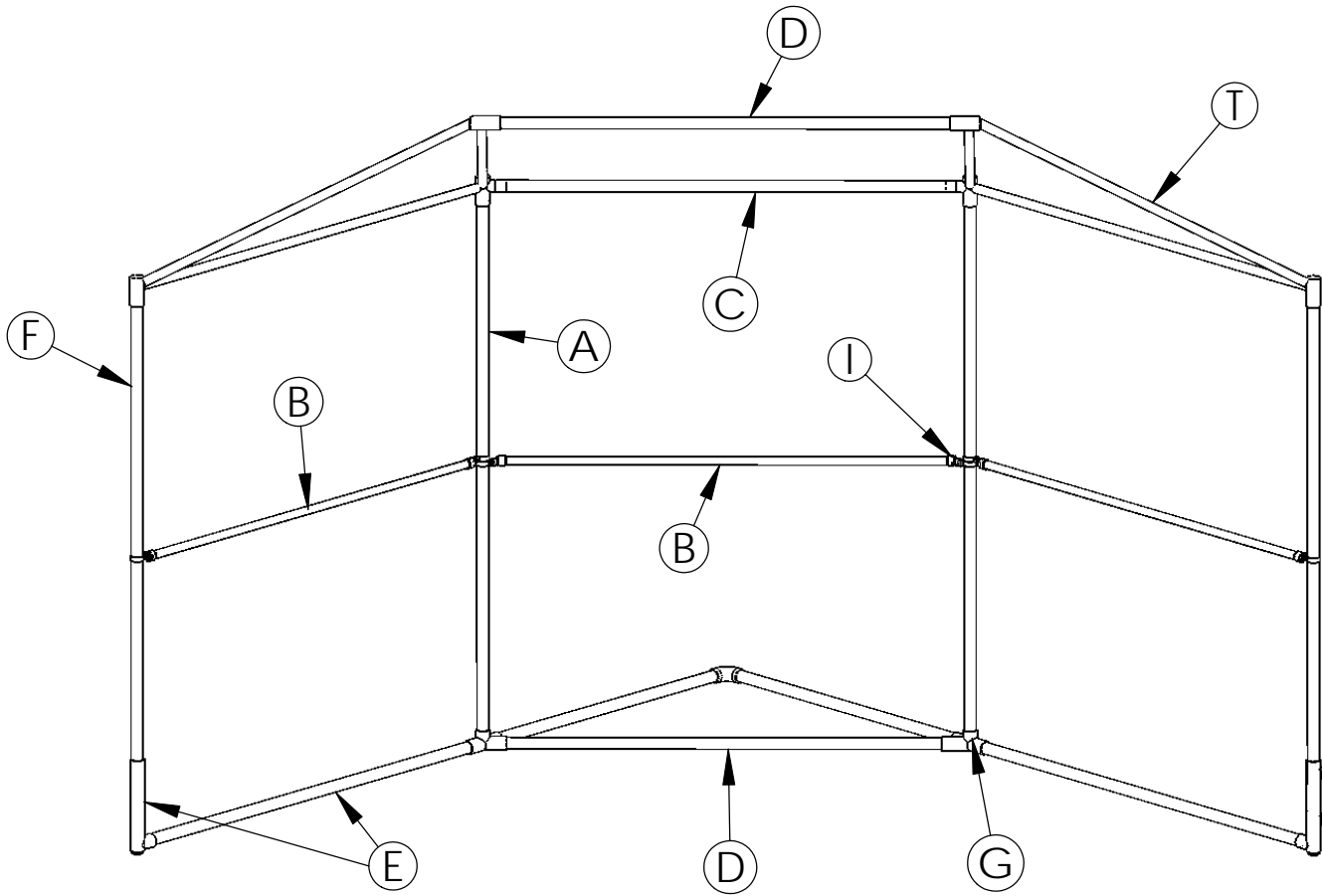

**NOTE: SPECIFICATIONS ARE SUBJECT TO CHANGE**

DO NOT SCALE DRAWING

DATE: 10/5/09

DRAWN BY: AFS

# STEELCRAFT PRODUCTS

P.O. Box 90365 - Pasadena, CA 91109  
PHN 626-798-7401 FAX 626-798-1482

MODEL  
810JH-4S  
PORTABLE  
BASEBALL BACKSTOP

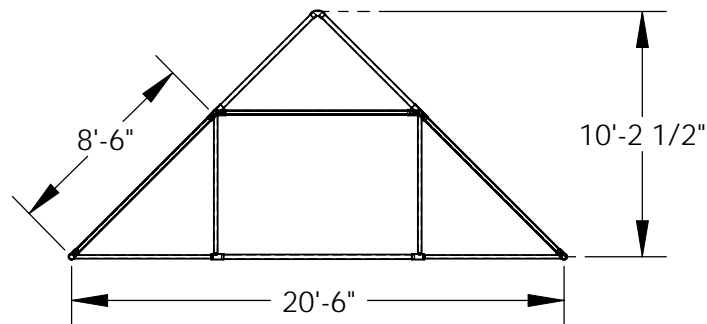

PLAN VIEW

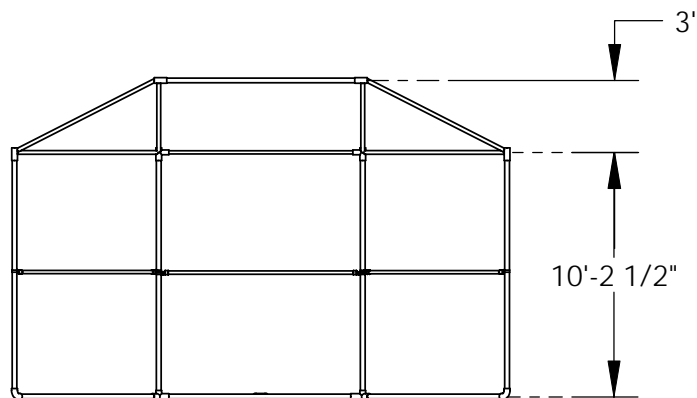

FRONT VIEW

## ASSEMBLY INSTRUCTIONS

1. Assemble the two skids (E) on the ground to form a right angle. Slide the 3 way fittings (G) on each skid pipe. Note that there are right and left hand units.
2. Attach the three elbow fittings (F) to each end of the skid pipe.
3. Insert the cross brace pipe (D) into the 3 way fittings between the skids.
4. Assemble the four uprights (A) into the fittings and attach the two pre-fab corner sections (Z) and secure with the set screws.
5. Attach the front rail (D) into the pre-fab sections and secure with set screws.
6. Attach the three horizontal pipe braces (B) with the rail end fittings (H) and brace bands (I).
7. Straighten framework and securely tighten all set screws using a hammer and socket key.
8. Attach the 11 ga. fabric to the center hood section. Weave the two tension bars (M) into last loop on each side of the fabric and attach to the pre-fab frames with tension bands (K). Use six on each side. Stretch fabric tight.
9. Measure the distance on the vertical panels so you can cut the 9 ga. fabric to the proper length. Unweave one strand of wire and then insert a tension bar (L) into the last loop of each end. Place the panel between two posts with the tension bars adjacent to the post and attach in the same manner as the hood section using tension bands (J). Stretch fabric tight.
10. Assemble the remaining two panels in the same manner. Using the tie wire (N), fasten fabric to the horizontal braces (B), skids (E), pre-fab corners (Z) and bottom brace (D).

**NOTE: SPECIFICATIONS ARE SUBJECT TO CHANGE**

DO NOT SCALE DRAWING

DATE: 10/5/09

DRAWN BY: AFS