

STEELCRAFT PRODUCTS

P.O. Box 90365 - Pasadena, CA 91109
PHN 626-798-7401 FAX 626-798-1482

MODEL
1054T
BASEBALL BACKSTOP

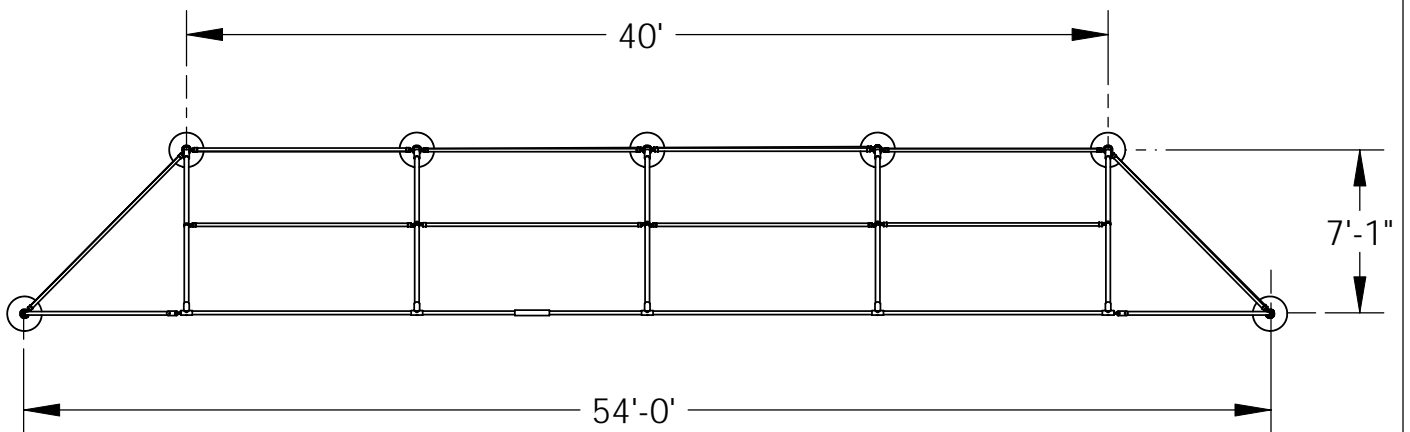
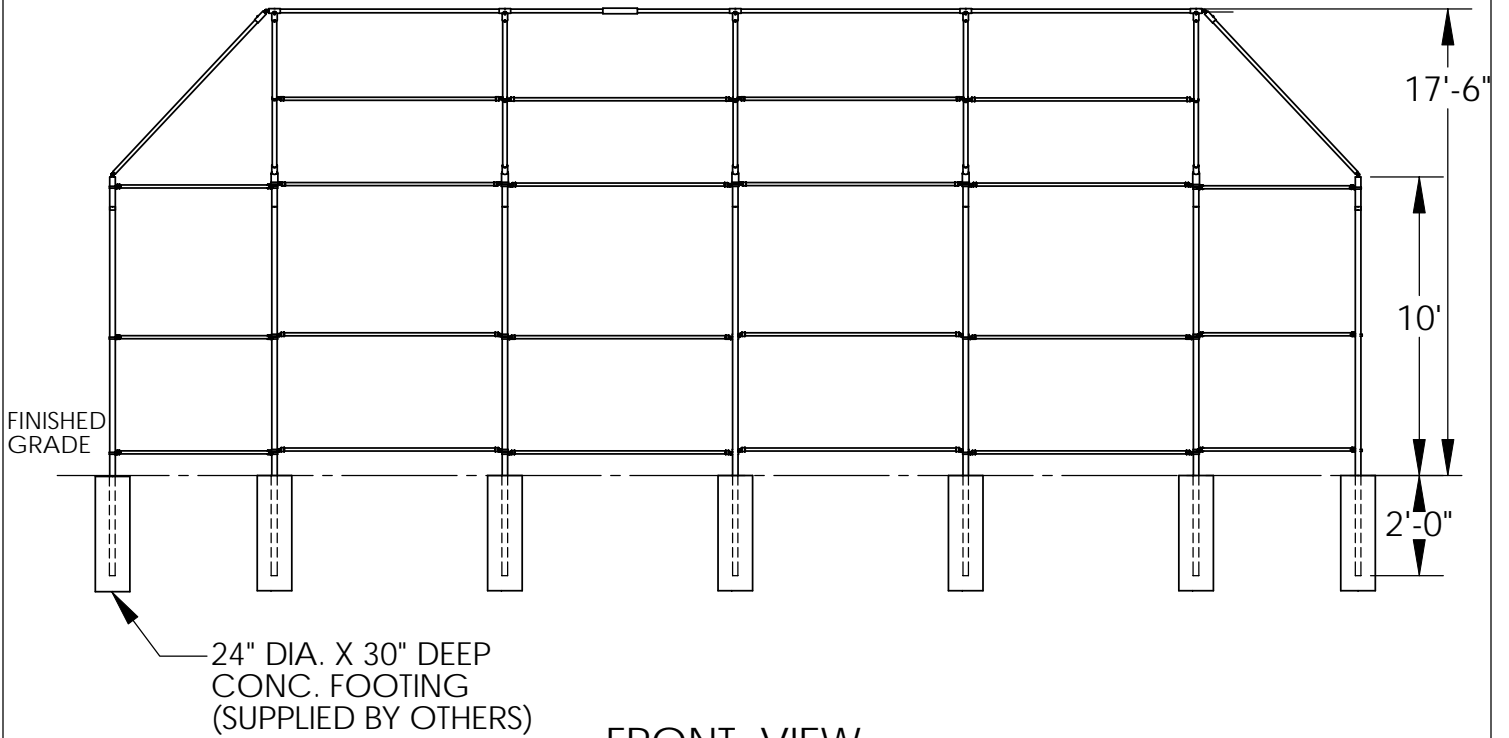

NOTE: SPECIFICATIONS ARE SUBJECT TO CHANGE

DO NOT SCALE DRAWING

DATE: 11/03/07

DRAWN BY: AFS

STEELCRAFT PRODUCTS

P.O. Box 90365 - Pasadena, CA 91109
PHN 626-798-7401 FAX 626-798-1482

MODEL
1054T
BASEBALL BACKSTOP

ASSEMBLY INSTRUCTIONS

1. Dig seven (7) holes @ 24" dia and 30" diam as shown on the plan view.
2. Place the three 2-7/8" od back posts (A) in the three back holes.
3. Place the two 2-7/8" od end posts (B) in the end holes with lugs parallel to the front opening.
4. Each post shall be 10'-0" above ground and 10'-0" on center. Place a horizontal brace (C) on the ground between each of the posts. Place a rail end fitting (P) on each end of these braces. Place a brace band (Q) over each post adjacent to each rail end fitting. Bolt rail end fitting to the corresponding brace band. Make sure the horizontal brace fits in to the rail end fittings at least 1". If they don't, adjust the posts accordingly.
**NOTE: All carriage bolt heads are facing the playing field.
5. With the proper spacing assured, plumb all posts and pour the concrete footings. Allow 24 hrs. for concrete to set and then proceed as follows.
6. Attach three angle fittings (G) to back posts (A).
7. Hood Post Erection: Insert the three hood support posts (D) into open end of the three angle fitting (G) on back posts, with bent portion toward the playing field.
8. Tighten set screws holding hood posts in place.
9. Install mid (C) and front (E) horizontal tie members, using three "T" fitting (H). Attach triangle supports (F).
10. Install horizontal braces (C) between the posts above ground. These braces can be installed in a manner similar to directions in item 4. Larger size bands (M) and (R) are furnished for use on the angle fittings.
11. Unroll the 9 ga wire (I) from end of roll. Stretch the wire for measuring and open the knuckle on each side of the roll at 9'-7" and weave out one strand of wire.
12. Weave a tension bar (L) through the last loops on the unknuckled sides. Place this wire against playing field side of one of the wing panels with the tension bars parallel to the uprights.
13. Stretch wire on the wing panels. Slip 6 tension bands (N) over each post adjacent to the tension bars. The tension bars must be offset so that the wire will be stretched on the playing field side (inside) of the backstop. Equally space the 6 tension band up and down the posts on each side of the wire panel and bolt into position.

**NOTE: If the wire is too loose, remove a strand of wire as in item 11 above or, if the wire is too tight to fasten into position, reweave into panel, the strand of wire removed in item 11 above.
14. Stretch Wire Back Panel The back two panels will be stretched in one piece between outside back posts (A). The length of the wire needed should be 3" shorter than the distance between the inside of the two corner posts (A). (Make sure wire is stretched when measuring)
15. Place this wire against the playing field side of the backstop with the tension bars (L) parallel and adjacent to posts (A). Stretch and secure into position with 6 tension bands (N) on each post.
16. Install and stretch wire in the opposite wing as described in items 12 and 13 above.
17. Stretch Wire - Hood Panels Install wire on hood, one panel at a time. Measure out the 11 ga chain link (J) wire as in item 12 above. and install as in item 13.
**NOTE: Wire goes on the outside (top) of hood.
18. Stretch Wire - Corner Panels Install wire on corner panels using 11 ga chain link (K) wire. Cut off extra wire where necessary. Tie at 12" along top side panels.
19. Use tie wire (O) and tie all chain link to the adjacent horizontal braces at approx. 18" apart.
20. Tighten all set screws and bolts & nuts.

DO NOT SCALE DRAWING

DATE: 11/03/07

DRAWN BY: AFS